

ITEM	QTY.	PART NUMBER	MATERIAL	MATERIAL THICKNESS	DESCRIPTION	PRODUCT NUMBER
1	1			12 ga	WLD, 4' X 6"W V-BTM CENTER OUTLET	TDA-BODY-6VC-04
2	1			14 ga	BASKET, 6"W V-BTM CENTER OUTLET	TDA-BSKT-6V
3	2			7 ga-3/16"	BAR GRATING 24X9	TDA-CVBG-09X24

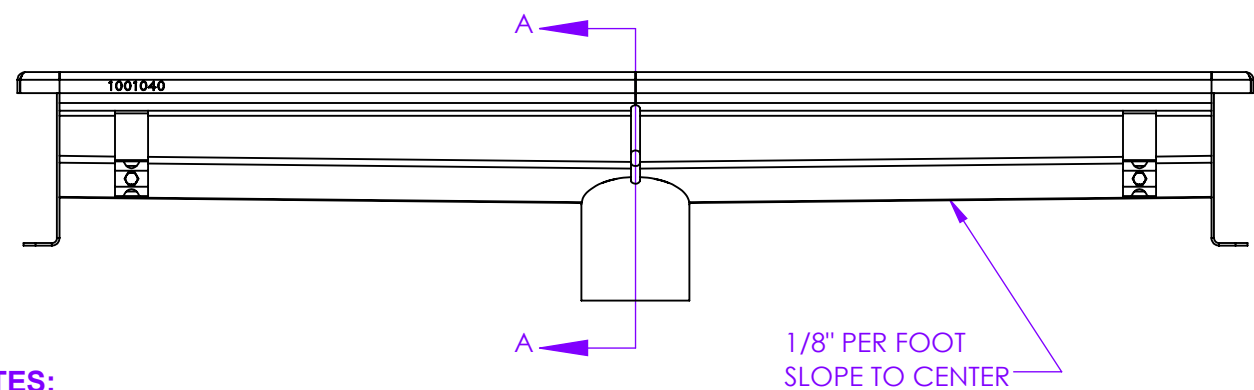
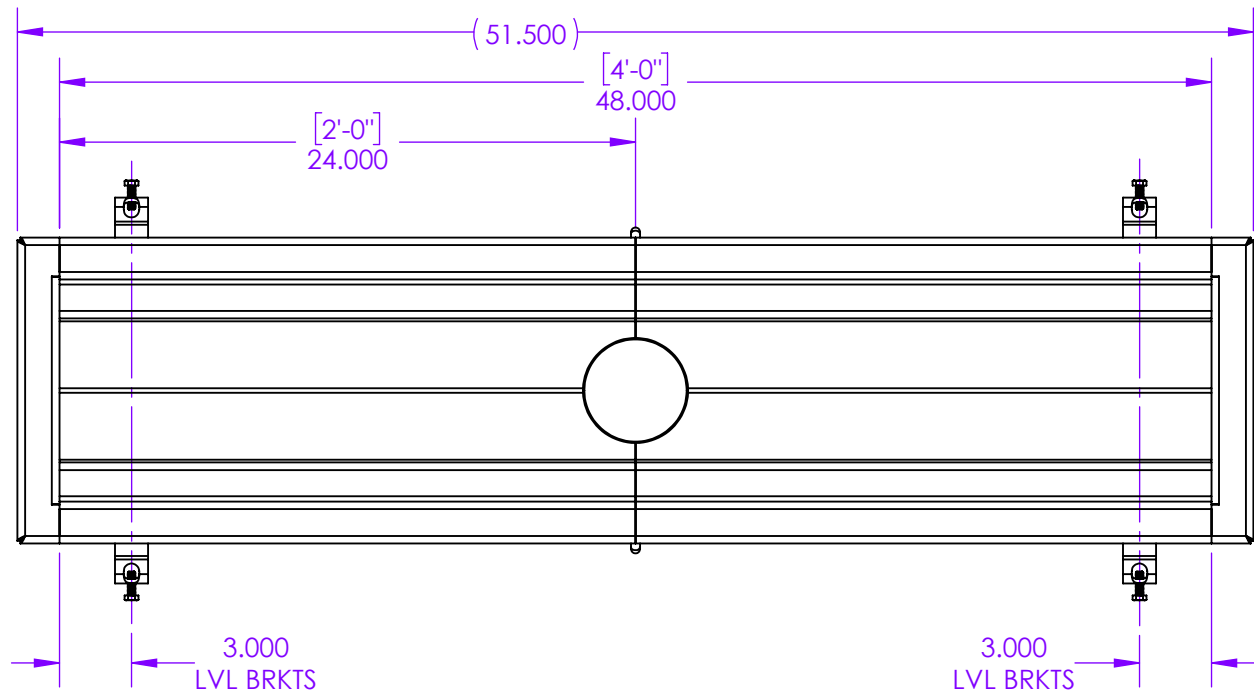

NOTES:

CONSTRUCTION

- TRENCH BODY 12GA 304 2B
- 304 4" SCH10 OUTLET
- 304 Ø3/8" CEMENT ANCHORS
- 304 LEVELING BRACKETS
- 1/8" PER FOOT SLOPE TO END
- ALL I.D. WELDS CONTINUOUS TIG WELDED, UNLESS NOTED
- ALL O.D. WELDS CONTINUOUS MIG WELDED, UNLESS NOTED
- ALL ANCHORS MIG WELDED AROUND, UNLESS NOTED
- I.D. WELD DISCOLORATION REMOVED, O.D. DISCOLORATION TO REMAIN

COVER(S)

- 3/16" 304 PLATE BAR GRATING

BASKET(S)

- 14GA 304 1/8" X 3/16" PERF
- TIG WELDED O.D.

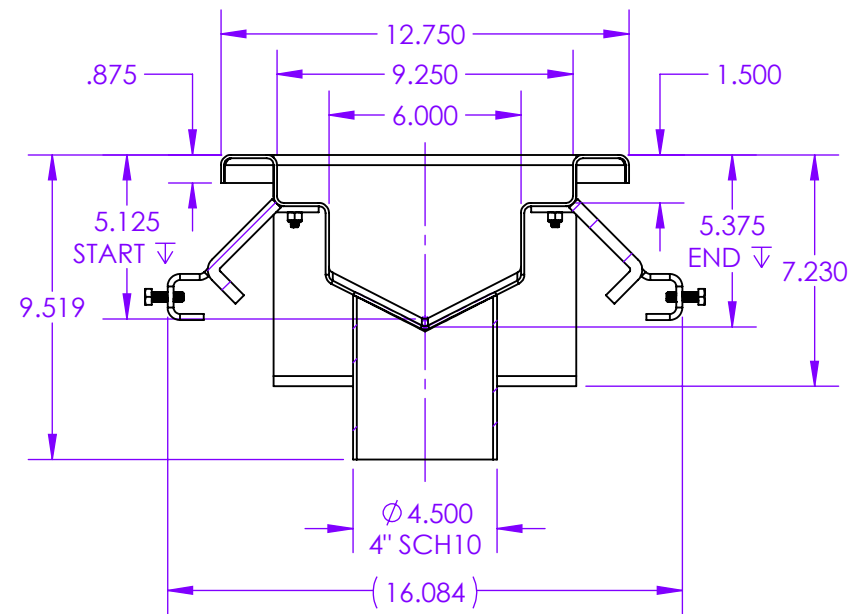
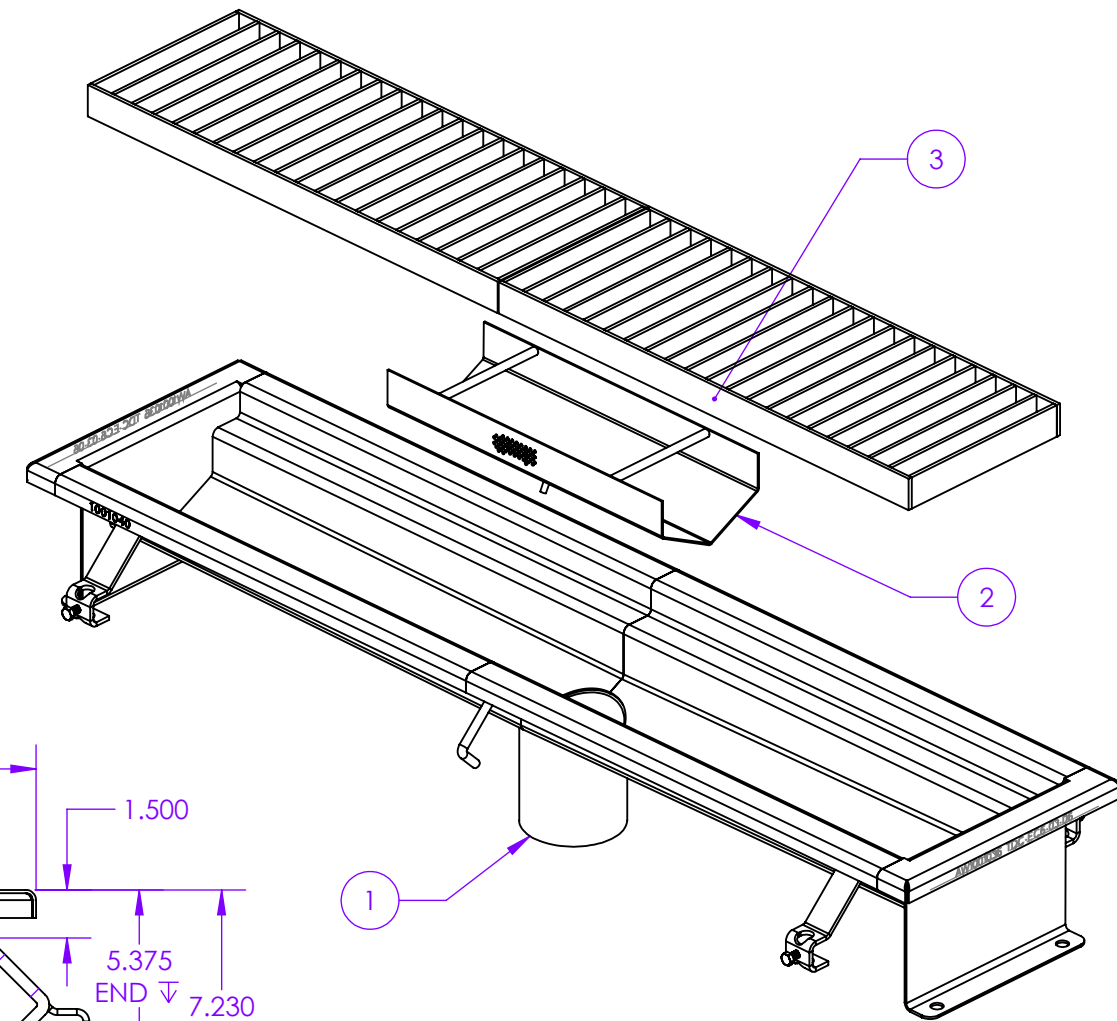

SECTION A-A
SCALE 1 : 6

	REVISION	VERSION
	-	2
	Standard Tolerances	
	Standard Tolerances	
	Pearson Potts - CustomDrains.com	